



KNIGHT 1  
KNIGHT 2  
KNIGHT 3  
KNIGHT 4  
KNIGHT 5

# KNIGHT series



**User Manual**



## Contents



The “Knights” series is the new entry level loudspeaker range from Castle. Whilst still retaining the hand built craftsman finished real wood veneers, for which Castle products are famous, value-engineered components and simplified construction techniques are used in this series without compromising either build quality or sonic performance.

The stand mount / bookshelf speakers are reflex designs with narrow, deep cabinets and rear reflex ports. The floor standing speakers feature Castle's own quarter wavelength speaker loading system – a special form of transmission line in which smooth low frequency extension is achieved without the usual upper bass “hot” zones found in many reflex loaded speakers. The line terminates in a port under the speaker and its output unobtrusively augments the main driver output. All the speakers feature bi-wireable terminals..

The new Knights series retains all the traditional virtues of impeccable design and presentation – a perfect balance of form and function in a remarkable value-engineered package.

Good Practice Guide.....	2
Unpacking the Equipment .....	3
Fitting Spikes.....	3
Cables and Connectors .....	4
Crossovers.....	5
Positioning your Loudspeakers .....	6
Connecting your Loudspeakers .....	7
Specifications .....	8
Final Thoughts.....	9
Service and Warranty.....	9

## Foreword

Before connecting and using your loudspeakers, please bear the following points in mind:

- Switch off the amplifier and all sources before making connections to your sound system. When you switch on the system or change sources, set the volume control to minimum and turn up the level gradually.
- The position of your volume control is NOT a reliable guide as to the maximum capabilities of your sound system. Playing the system with extreme settings of volume and tone controls may damage the amplifier and loudspeakers.
- Do not connect loudspeaker terminals to the mains supply.
- Ensure that your loudspeakers are correctly wired and are in phase.
- Do not subject your loudspeakers to excessive cold, heat or sunlight.
- If you are shelf mounting your loudspeakers, make sure they are not placed on the same shelf as your source components.
- Do not place heavy objects on top of loudspeaker cabinets.
- The product must not be exposed to dripping and splashing and no object such as a vase of flowers should be placed on the product.
- Lighted candles must not be placed on the product.
- If you play the loudspeakers with the grilles removed be careful to protect the drive units from children and pets.
- Do not use makeshift stands. Always fit a manufacturer's approved stand using the instructions and the fixings provided. Your dealer will advise you.
- Do not attempt to dismantle the loudspeaker. There are no user serviceable parts inside and you will invalidate the warranty.
- You should site all Castle Knights loudspeakers at least 0.5 m away from TV sets and magnetic storage media. All Castle centre loudspeakers may be sited close to a TV screen with no adverse effects.
- When connecting your loudspeakers, do not run cable across areas of open floor where they may be a source of danger. Run them safely, around room boundaries if necessary.

## Unpacking Your Loudspeakers

- Now you have opened the carton, we hope you are reading this manual.
- If you are unpacking the larger loudspeakers remember that these units are heavy. We suggest that you have someone to assist you.
- Lift the loudspeaker carefully out of the packing. Do NOT try and lift the loudspeaker using the cloth bag.
- Unpack any accessories carefully.
- If there is any sign of damage or if the contents are incomplete, report this to your dealer as soon as possible.
- Retain the packing for future safe transport of the product. If you dispose of the packing, do so with respect to any recycling provisions in your area.
- Stand mounting loudspeakers are ready to be connected after unpacking. The larger loudspeakers will need to be assembled on their plinths and spike kits.

## Attaching the Plinth and Spikes to Floorstanding Models

- Ensure you have plenty of unobstructed working space.
- Place a soft cloth on the floor to protect the loudspeaker.
- Invert the loudspeaker onto the cloth.
- Thread a locknut onto each spike and loosely run it up the thread.
- Thread the spikes onto the spike inserts. Tighten them finger tight.
- Thread a spike knob on to the head of each spike.
- Place the spacing washers over the holes as indicated.
- **Attaching the Plinth:** Place the plinth on the loudspeaker. Place a washer over each of the four round head screws. Insert the screws into the threaded holes on the loudspeaker and tighten securely.
- Invert the loudspeaker. Be careful not to damage the floor with the spikes.

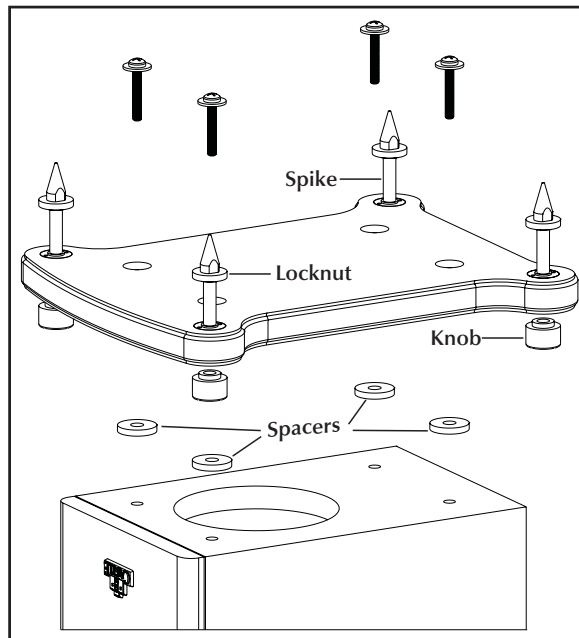

## Levelling the Loudspeakers

### When the speaker is upright:

- You will probably find that the speaker will wobble with one spike not contacting the floor. Adjust this spike until all four spikes are on the floor. With the aid of a spirit level move each spike in and out until the loudspeaker is level and sitting squarely on all four spikes with no rocking.
- Now tighten each locknut securely against the collar in the plinth to secure the spike.
- Thread the knob onto the spike and tighten to secure the assembly.
- A spike seat is provided for use on wood or stone floors etc. and should be placed as shown.

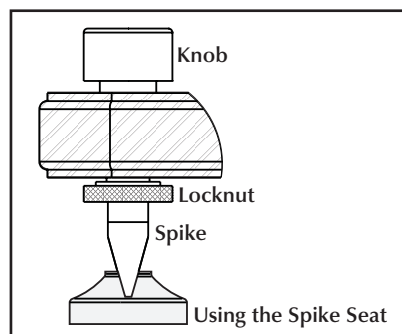

## Important notes on floorstanding loudspeakers:

- The plinth is an integral part of the design. Do NOT use floorstanding loudspeakers without the plinth properly attached.
- The spacers lift the base of the loudspeaker off the plinth by a precisely calculated amount. This space forms the exit path for the Quarter Wave transmission line. On no account should these spacers be omitted or substituted as this will seriously impair the low bass performance of your loudspeakers.

## Cables and Connectors

### Choosing Loudspeaker Cable

Specialist audio cable usually offers better performance than general purpose 'bell' or 'zip' wire.

Choose a cable of suitable diameter – cable that is too thin will limit the dynamics of the sound and may impair the bass response. Audio cable is polarised, with two cores of different colours, or often a raised rib or coloured tracer in the case of twin cable.

Before you purchase your cable, we suggest that you give careful thought to the positioning of your loudspeakers. This is especially the case if you are bi-wiring your loudspeakers.

Cable lengths to loudspeaker pairs should be the same for left and right channels in order to equalise the signal transmission. Allow some slack in your speaker cables so you can alter their position to best advantage, but do not have your cables over-long.

### Preparing Loudspeaker Cable

Split the twin cores to a depth of about 40mm. Carefully strip the insulation from each end, leaving about 10mm of bare wire. If the cable is stranded, lightly twist to gather any loose strands.

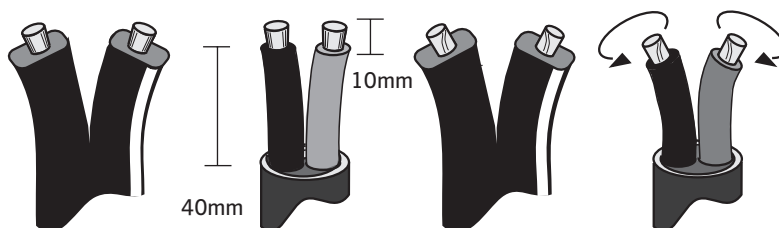

### Connecting Screw Terminals

All the loudspeakers use screw terminals.

#### Safe Connection of Terminals

Unscrew the terminal. Insert the bare end of the cable into the hole in the base of the terminal. Tighten securely.

When connecting terminals, make sure you leave no strands of bare wire that can short across to adjacent terminals.

As an alternative to bare wire you can use specialist spade connectors. Your Castle dealer will be pleased to advise you.

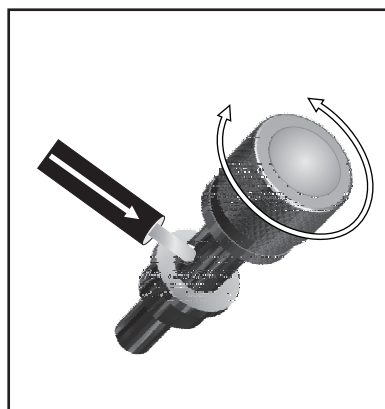



## Crossover Networks

*The Castle Knights Series use bi-wired terminal panels.*

### Biwireable Crossovers

A bi-wiring panel has four terminal binding posts. The upper terminals connect to the treble units, the lower pair to the bass unit.

As supplied the treble and bass terminal pairs are connected via removeable straps. This arrangement facilitates standard single wiring, and advanced bi-wiring which offers significant performance advantages. Follow the drawings carefully to see the correct orientation of the loudspeaker terminals.

### Why Bi-Wire?

Bi-wiring involves the use of two separate cables between the amplifier and the loudspeakers. One pair connects to the treble unit the other to the bass driver.

Using separate cables for treble and bass units in a Bi-Wiring configuration reduces intermodulation effects and improves headroom and clarity. To bi-wire, you will need to install two lengths of twin core cable between the amplifier and each loudspeaker.

### Bi-amplifying

The bi-wiring principle can be further extended by bi-amplifying (bi-amping). To bi-amp you will need two amplifiers per loudspeaker. One amplifier is connected to the treble terminals and the other to the bass terminals of the crossover panel. Bi-amping offers the greatest clarity. Because each amplifier is working over a narrow range, intermodulation distortion is virtually eliminated and acoustic performance optimised.

The amplifiers in the treble and bass sections of a bi-amped loudspeaker need not be identical but they must exhibit the same phase characteristics. If you wish to bi-amp your loudspeakers we suggest you consult your Castle dealer if you are in any doubt.

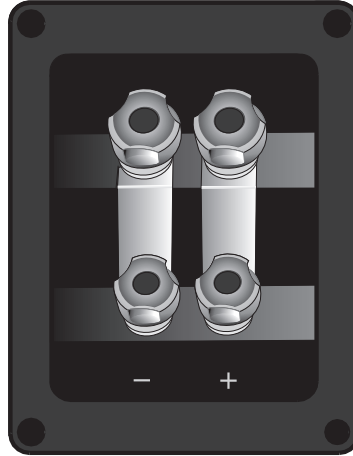

*As supplied*

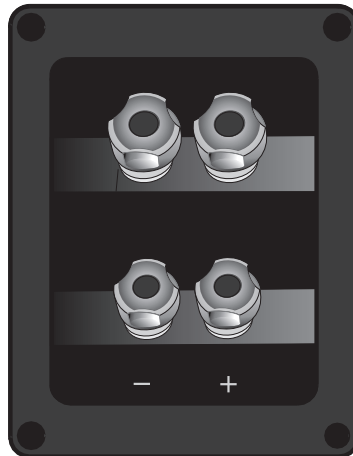

*In bi-wiring mode*

## Positioning Stereo Loudspeakers

The distance between the speakers should be the same as between you and the speakers.

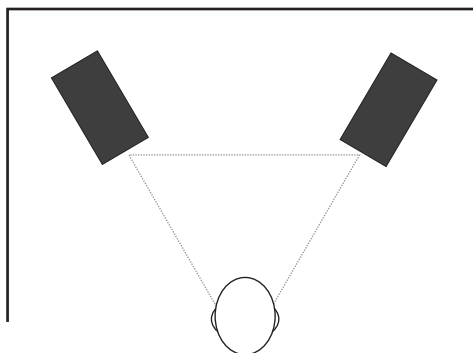

If the loudspeakers are placed too close to the walls, the bass will increase but may be boomy and indistinct. If the loudspeakers are placed further away from the walls, the inward angle ("toe in") may be increased by up to 30%. As personal taste plays a large role, experiment with different configurations and play a wide range of programme material before finalising the position of your speakers.

The optimum listening position is in the area broadly known as the 'sweet spot'. The more extreme the angle, the narrower is the sweet spot. Castle loudspeakers are designed to cover a medium sonic perspective so there should be no need for extreme settings.

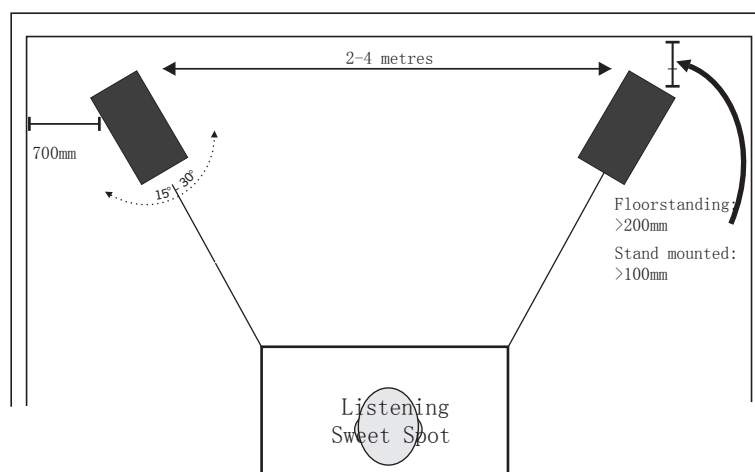

## Stand Mounting Loudspeakers

The Knight 1 and Knight 2 are designed for stand mounting. The stands should be sturdy and offer optimum support for the loudspeaker. As an alternative the speakers may be wall mounted on rigid brackets or placed on rigid shelves.

Ideally the tweeter should be at ear level to a seated listener. If the rear panels of the speakers are placed close to the walls, the amount of bass will be increased but the clarity may well suffer - you should experiment until you get the best result.



## Connecting Your Loudspeakers

### Standard Loudspeaker Wiring

Choose a suitable length of twin core speaker cable for each channel, and prepare the ends. Unscrew each terminal a few turns.

Connect the red, positive (+) terminal of the Left loudspeaker to the corresponding red, positive (+) amplifier terminal.

Connect the black, negative (-) terminals similarly. Tighten the terminals securely.

Repeat this procedure for the Right Channel.

If you are standard wiring a bi-wiring panel, make sure that the binding straps are securely in place.

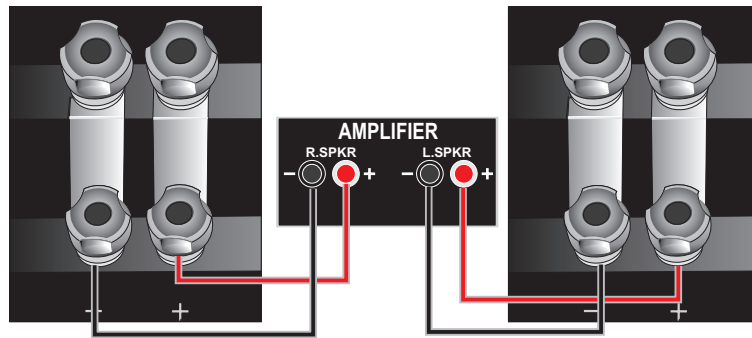

*Right Speaker*

*Left Speaker*

### Bi- Wiring

To Bi-wire, you will need to install two lengths of twin core cable between the amplifier and each loudspeaker.

**Note:** Some amplifiers have two pairs of output terminals to facilitate bi-wiring but this is not essential. The advantages of bi-wiring are fully retained if your amplifier has only one pair of loudspeaker terminals per channel (as in the illustration).

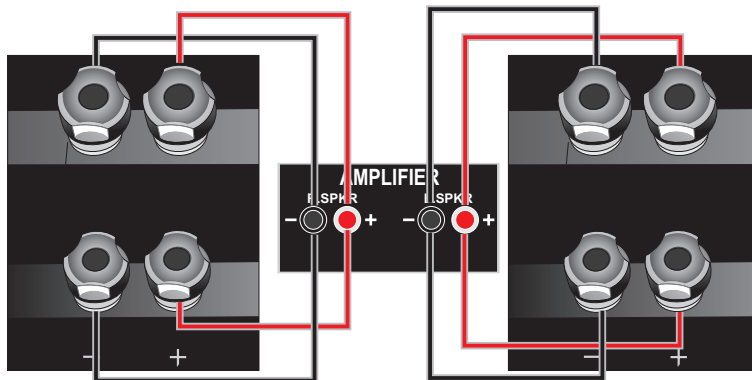

*Right Speaker*

*Left Speaker*

### Bi- Amping

Two amplifiers are used. One amplifier is connected to the treble terminals the other to the bass terminals.

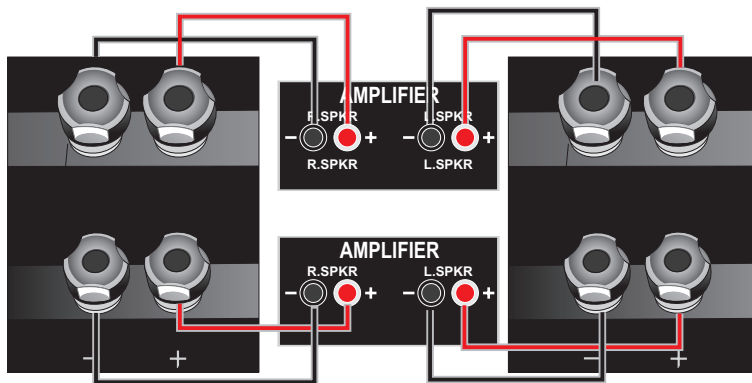

*Right Speaker*

*Left Speaker*

### Phase

It is essential that you strictly observe the colour code when connecting your loudspeakers. Incorrectly connected (out of phase) loudspeakers suffer from poor bass response and fuzzy imaging. Phase anomalies in high fidelity systems can be extremely annoying and, especially when the speakers are bi-wired or bi-amped, difficult to pin down. A correctly connected Castle loudspeaker system will give you deep sonorous bass with pinpoint imaging and clarity.

## Specifications

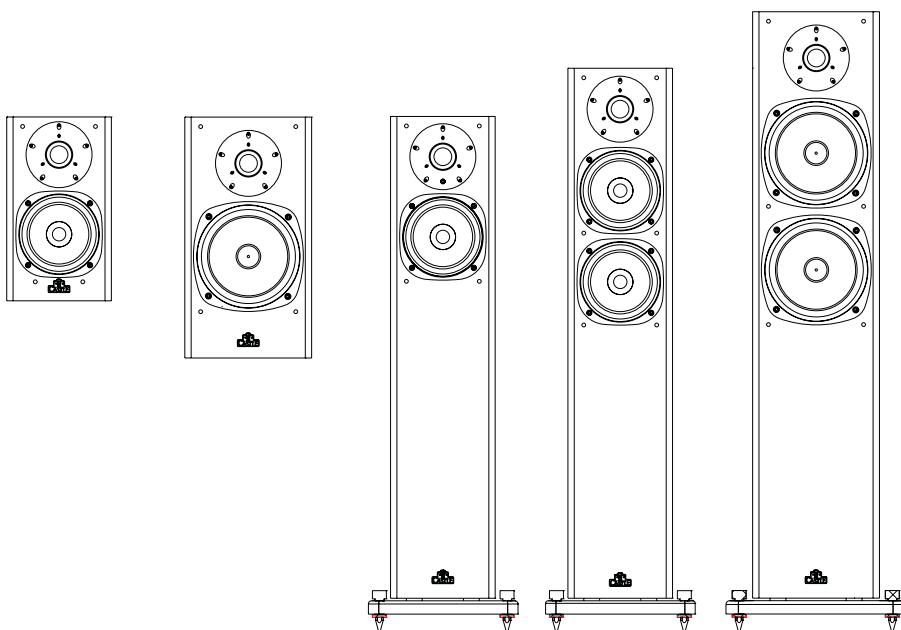

### KNIGHTS SERIES

Parameter	Knight 1	Knight 2	Knight 3	Knight 4	Knight 5
<b>Function</b>	2 channel	2 channel	2 channel	2 channel	2 channel
<b>Format</b>	Stand Mount	Stand Mount	Floorstanding	Floorstanding	Floorstanding
<b>Operating Mode</b>	Reflex	Reflex	Quarter Wave	Quarter Wave	Quarter Wave
<b>Bass Driver</b>	130mm	150mm	130mm	2 x 130mm	2 x 150mm
<b>Tweeter</b>	25mm	25mm	25mm	25mm	25mm
<b>Amplifier power (rec.)</b>	15 - 100W	15 - 125W	15 - 100W	25 - 150W	25 - 200W
<b>Impedance (Nominal)</b>	8 Ohms	8 Ohms	8 Ohms	8 Ohms	8 Ohms
<b>Sensitivity (1W@1M)</b>	88 dB	90 dB	88 dB	90 dB	91 dB
<b>Nominal Frequency Range</b>	46Hz - 24kHz	42Hz - 24kHz	38Hz - 24kHz	36Hz - 24kHz	30Hz - 24kHz
<b>Freq. Fb</b>	55Hz	40Hz	50Hz	45Hz	35Hz
<b>Crossover Frequency</b>	3 kHz	3 kHz	3 kHz	3 kHz	3 kHz
<b>Dimensions (HxWxD) (mm)</b>	290 x 165 x 265	380 x 200 x 335	760 x 165 x 265	840 x 165 x 270	925 x 200 x 335
<b>Height on plinth and spikes</b>	—	—	820	900	985
<b>Net weight</b>	4.5 kg (9.9 lbs)	7.85 kg (15.7 lbs)	10.7 kg (23.5 lbs)	12.5 kg (27.5 lbs)	20 kg (44 lbs)
<b>Carton size (mm)</b>	450 x 330 x 370	520 x 400 x 460	890 x 330 x 450	970 x 330 x 450	1055 x 280 x 400
<b>Gross weight</b>	10.2 kg (22.4 lbs)	17.6 kg (38.7 lbs)	23.5 kg (51.7 lbs)	27.1 kg (59.6 lbs)	22.2 kg (48.8lbs)
<b>Finishes</b>	Specially selected Deep Figured Veneers sealed with "natural feeling" semi matt clear lacquer				

## Final Thoughts

### Looking After Your Loudspeaker

- Your Castle Loudspeakers use a specially hardwearing sealed finish. They should not be waxed or treated with spray polishes which will smear and dim their lustrous finish. Occasionally polish them with a dry or barely moist cloth to remove dust and finger marks, etc.
- Occasionally, remove the loudspeaker grilles and brush them gently with a soft brush before replacing them carefully.
- Never stand objects on your loudspeakers. In particular do not stand flowers etc. on them - they are not jardinières!
- Avoid getting any liquid behind the grille. If you accidentally spill liquid on your loudspeakers, take them to your dealer for attention before using them again.
- Do not open the speakers; there are no user serviceable parts inside. Never touch the drive units either with an object or your hands.

### Quality Assurance

Your Castle loudspeakers have been constructed to the highest standards. From the top grade furniture construction and finish to the carefully designed and selected acoustic components, the Castle range is a testament to fine design, fine engineering and fine craftsmanship. Our speakers are built to provide a lifetime of pleasure to the eye, the ears and through the music they play, the soul. We hope you will derive many years of good service from our products.

### Servicing

Servicing of Castle products should only be carried out by authorised service agents. If service is required the equipment should be returned, securely packaged, preferably using original packaging, to your dealer.

In the UK equipment may be returned to the IAG Service Centre. Always telephone before returning any equipment. A note should be enclosed giving your name, address, telephone number, and a brief description of the reason for return.

If you require service outside the Warranty period, do not hesitate to contact your dealer.

### Service Addresses

For technical support, servicing, product queries or information please contact either your local retailer or the main offices below.

#### UK

IAG Service Dept.  
Unit 4  
St Margaret's Way  
Stukeley Meadows Industrial Estate  
Huntingdon  
Cambs  
PE29 6EB  
England  
Tel: +44 (0)1480 452561  
Fax: +44 (0)1480 413403

#### Asia

IAG  
Room 2310 - 2311 Press Building,  
Shennan Road C,  
Shenzhen,  
China  
Tel: +86-755-82091200  
Fax: +86-755-82091205



IAG House, Sovereign Court, Ermine Business Park, Huntingdon, Cambs, PE29 6XU, UK  
Tel: +44(0)1480 447700 Fax: +44(0)1480 431767 <http://www.castle.uk.com>  
IAG reserve the right to alter design and specification without notice. All rights reserved © IAG Group Ltd.  
Castle Acoustics is a member of the International Audio Group.